

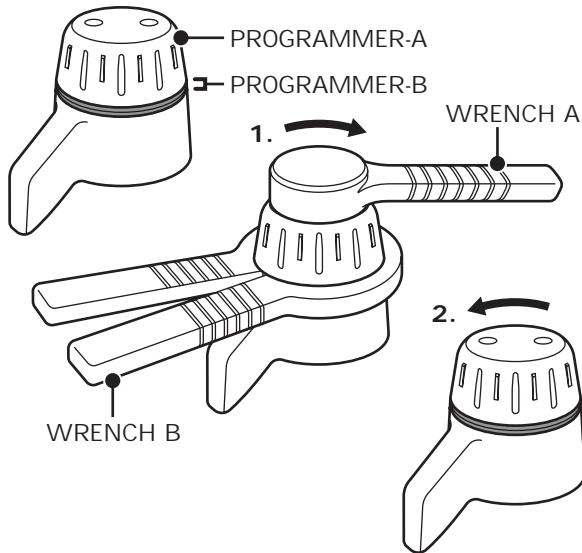

DISASSEMBLY OF THE DRAG

1. Firmly grasp PROGRAMMER-A using WRENCH A and PROGRAMMER-B using WRENCH B, then loosen PROGRAMMER-A by rotating WRENCH A in the direction of the arrow indicated by **1.** in the illustration below.
2. In the event that PROGRAMMER-B cannot be removed even after loosening PROGRAMMER-A, rotate PROGRAMMER-A and -B in the direction of the arrow indicated by **2.** in the illustration, then repeat the instructions in **1.** above.



ASSEMBLY OF THE DRAG

1. Screw in the PRESSURE SCREW by hand to the maximum depth it will screw in.
2. Next, place PROGRAMMER-A on top of the PRESSURE SCREW so that the  (OVAL KNOB) portion of the PRESSURE SCREW fits into the corresponding depression (oval recess) in PROGRAMMER-A. Applying a firm grip with WRENCH B to keep PROGRAMMER-B from turning, rotate PROGRAMMER-A in the direction of the arrow in the illustration below.
3. When PROGRAMMER-A reaches the point where it won't turn any further, rotate PROGRAMMER-A and -B as many times as possible in the opposite direction of the arrow in the illustration.
4. Once again applying a firm grip with WRENCH B to keep PROGRAMMER-B from turning, rotate PROGRAMMER-A in the direction of the arrow indicated in the illustration. Assembly is complete once PROGRAMMER-A and -B have been firmly screwed into place.

